

HS5B Miniature Interlock Switches

Available with a robust and durable metal head.

Choice of three conduit port sizes: G1/2, PG13.5, and M20

- Actuators are interchangeable with the HS5E interlock switches.
- Actuators with rubber bushings are ideal for rattling doors.
- Double insulation structure eliminates the need for grounding.
- The head orientation can be changed, allowing 8 different actuator entries.
- Degree of protection (contacts): IP67 (IEC60529)
- NC contacts are of direct opening action (IEC/EN60947-5-1).
- Dedicated actuators prevent unauthorized opening of the contacts (ISO14119, EN1088).
- Compact body: 30 × 30 × 91 mm



Interlock Switch

Contact Configuration	Conduit Port Size	Part No. (Package quantity: 1)	
		Plastic Head	Metal Head
1NC-1NO	G1/2	HS5B-11B	HS5B-11ZB
	PG13.5	HS5B-11NP	—
	M20	HS5B-11BM	HS5B-11ZBM
2NC	G1/2	HS5B-02B	HS5B-02ZB
	PG13.5	HS5B-02NP	—
	M20	HS5B-02BM	HS5B-02ZBM

Actuators

Description	Part No. (Package quantity: 1)
Straight Actuator	HS9Z-A51
Straight Actuator w/rubber bushing	HS9Z-A51A
Right-angle Actuator	HS9Z-A52
Right-angle Actuator w/rubber bushing	HS9Z-A52A
Angle Adjustable Actuator (for hinged doors)	HS9Z-A55
Sliding Actuator (Note)	HS9Z-SH5

Note: See page 76 of catalog no. EP1452 for sliding actuator.

Parts Description

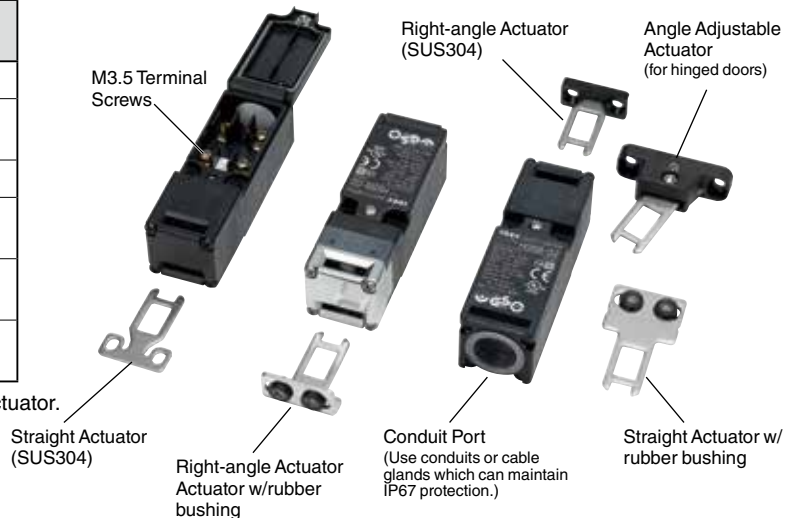

HS5B Miniature Interlock Switches

Part No. Development

HS5B - 11 Z BM	
Circuit Code	Head Housing Color / Conduit Port
11: 1NC-1NC	B: Black / G1/2
02: 2NC	BM: Black / M20
	NP: Gray / PG13.5
Head Material	
blank: Plastic	
Z: Metal	

Contact Ratings

Rated Insulation Voltage (Ui)		300V			
Rated Current (Ith)		10A			
Rated Voltage (Ue) *		30V	125V	250V	
Rated Current (Ie) *	AC	Resistive load (AC-12)	10A	10A	6A
		Inductive Load (AC-15)	10A	5A	3A
	DC	Resistive load (DC-12)	8A	2.2A	1.1A
		Inductive Load (DC-13)	4A	1.1A	0.6A

- Minimum applicable load (reference): 3V AC/DC, 5mA
- * Ratings approved by safety agencies: A300 (UL/c-UL), AC-15 3A/250V (TÜV, BG)

Specifications

Applicable Standards	UL508 (UL listed) CSA C22.2, No. 14 (c-UL listed) ISO14119 EN1088 IEC60947-5-1 EN60947-5-1 (TÜV approval) GS-ET-15 (BG approval) GB14048.5 (CCC approval) IEC60204-1/EN60204-1 (applicable standards for use)
Applicable Directive	73/23/EEC (Low Voltage Directive)
Operating Temperature	-20 to +70°C (no freezing)
Relative Humidity	45 to 85% (no condensation)
Storage Temperature	-40 to +80°C (no freezing)
Pollution Degree	3
Impulse Withstand Voltage	4 kV
Insulation Resistance (500V DC megger)	Between live and dead metal parts: 100 MΩ minimum Between terminals of different poles: 100 MΩ minimum
Electric Shock Protection Class	Class II (IEC61140)
Degree of Protection	IP67 (IEC60529)
Shock Resistance	Damage limits: 1000 m/s ² (approx. 100G)
Vibration Resistance	Operating extremes: 10 to 55 Hz, amplitude 0.5 mm Damage limits: 30 Hz, amplitude 1.5 mm
Actuator Operating Speed	0.05 to 1.0 m/s
Direct Opening Travel	8 mm minimum
Direct Opening Force	60N minimum
Operating Frequency	900 operations per hour
Mechanical Life	1,000,000 operations minimum (GS-ET-15)
Electrical Life	100,000 operations minimum (operating frequency 900 operations per hour, load AC-12, 250V, 6A) 1,000,000 operations minimum (operating frequency 900 operations per hour, load 24V AC/DC, 100mA)
Conditional Short-circuit Current	100A (250V) (Use 250V/10A fast-blow fuse for short-circuit protection.)
Housing Color	Black (conduit port: G1/2, M20) Gray (conduit port: PG13.5)
Weight (approx.)	Plastic head: 80g Metal head: 110g

HS5B Miniature Interlock Switches

Dimensions and Mounting Hole Layouts

Metal Head

Using the HS9Z-A51 Straight Actuator

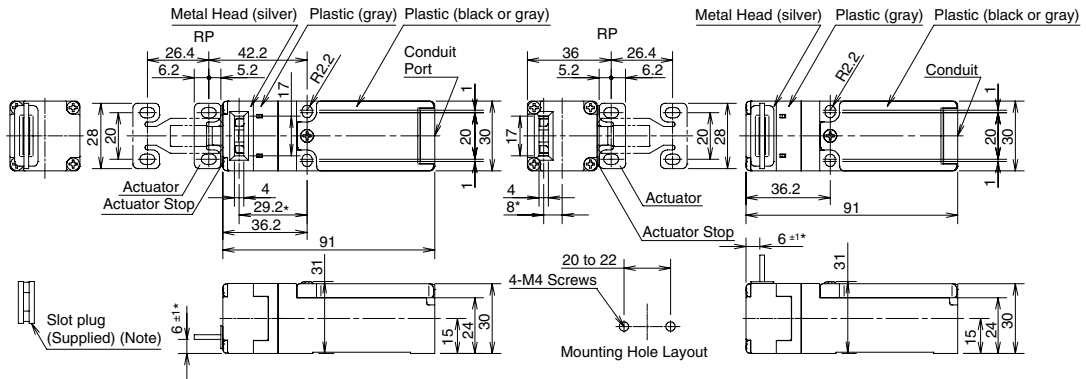

Using the HS9Z-A52 Right-angle Actuator

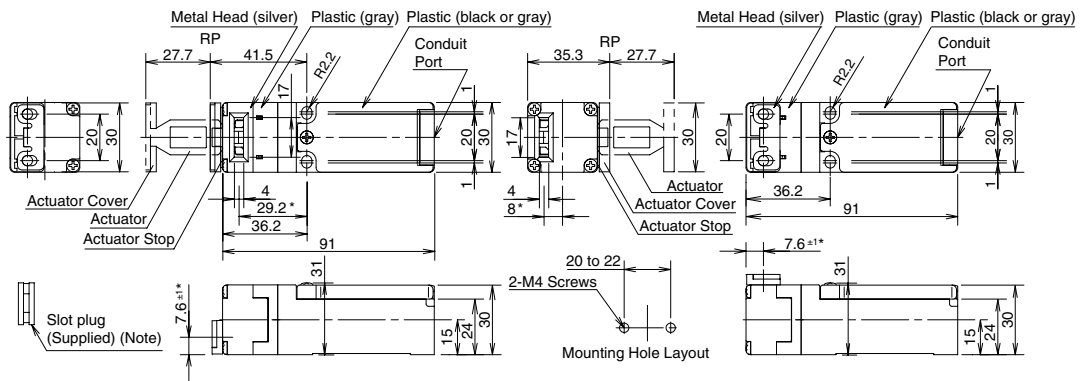

Plastic Head

Using the HS9Z-A51 Straight Actuator

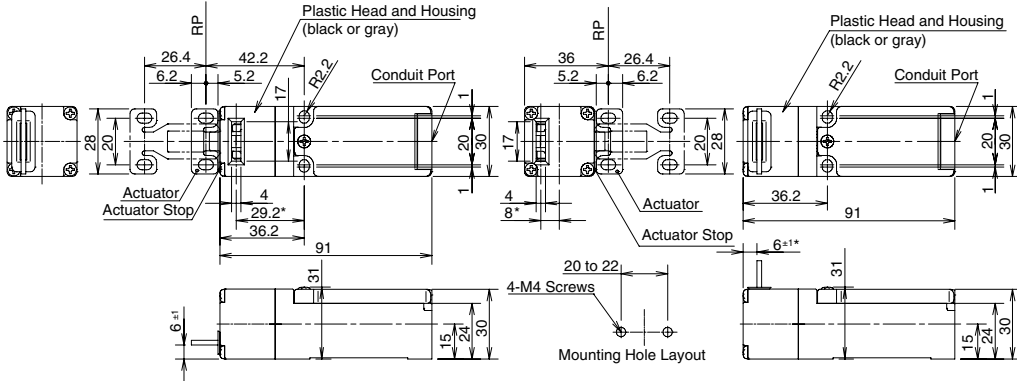

Using the HS9Z-A52 Right-angle Actuator

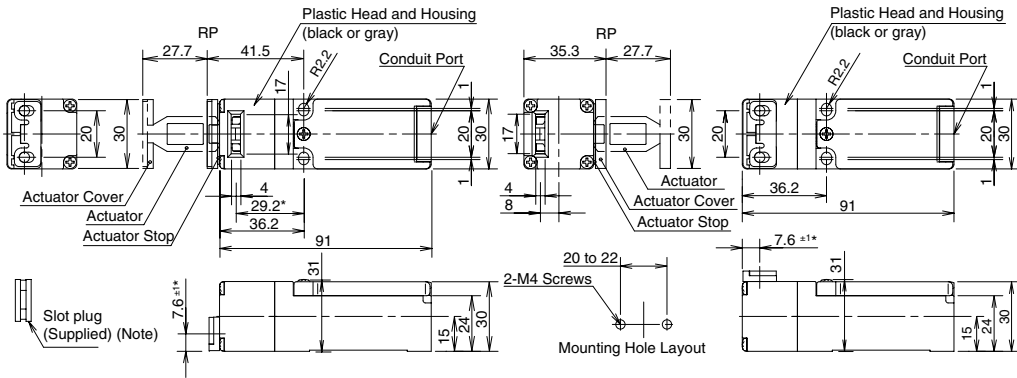

Note: Plug the unused actuator insertion slot using the slot plug supplied with the interlock switch.
* Actuator center position

All dimensions in mm.

HS5B Miniature Interlock Switches

Actuator Dimensions

Straight (HS9Z-A51)

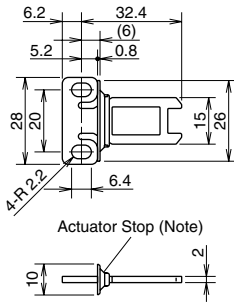

Right-angle (HS9Z-A52)

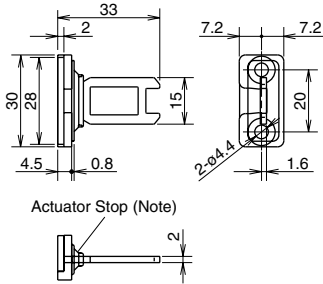

Straight w/rubber bushing (HS9Z-A51A)

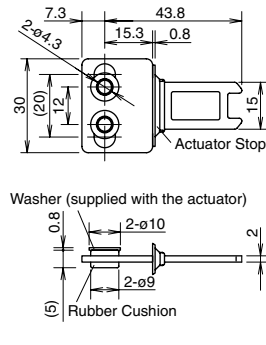

Right-angle w/rubber bushing (HS9Z-A52A)

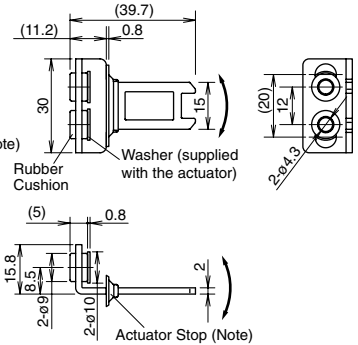

Actuator Mounting Hole Layout (Straight, Right-angle)

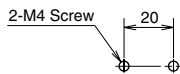

- The mounting center distance is set to 12 mm at factory. When 20-mm distance is required, adjust the distance by moving the rubber bushings.
- The actuator has flexibility to the directions indicated by the arrows. When 20-mm distance is selected, the actuator swings vertically.

Actuator Mounting Hole Layout (Straight w/rubber cushion) (Right-angle w/rubber cushion)

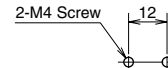

Mounting centers can be widened to 20 mm by moving the rubber cushions.

Angle Adjustable (HS9Z-A55)

Horizontal Swing

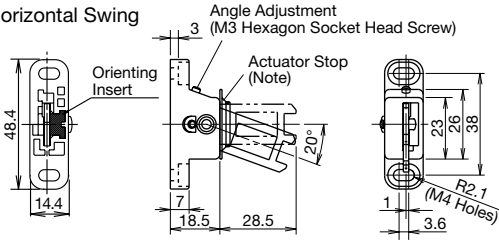

Vertical Swing

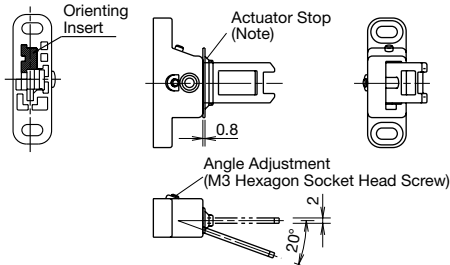

Note: The actuator stop is supplied with the actuator and used when adjusting the actuator position. Remove the actuator stop after the actuator position is determined.

Actuator Orientation (Angle Adjustable)

The angle of actuator swing can be changed using the orienting insert (white plastic) installed on the back of the actuator. Do not lose the orienting insert, otherwise the actuator will not operate properly.

Actuator Mounting Hole Layout (horizontal/vertical swing)

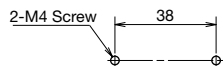

All dimensions in mm.

Contact Configuration and Operation Chart

Model	Contact Configuration	Contact Operation Chart	Contact Status
HS5B-11	1NC-1NO 		
HS5B-02	2NC 		

- The operation chart shows when using HS9Z-A51 actuator. When using other actuator, add 1.3mm.
- The operation chart shows when the actuator enters the center of actuator entry slot.

Safety Precautions

- In order to avoid electric shock or fire, turn power off before installation, removal, wire connection, maintenance, or inspection of the interlock switch.
- If relays are used in the circuit between the interlock switch and the load, use only safety relays, since welded or sticking contacts of standard relays may invalidate the functions of the interlock switch. Perform risk assessment and make up a safety circuit which satisfies the requirements of the safety category.
- Do not place a PLC in the circuit between the interlock switch

and the load. Safety security can be endangered in the event of a malfunction of the PLC.

- Do not disassemble or modify the interlock switch, otherwise a malfunction or an accident may occur.
- Do not install the actuator in the location where a human body may come into contact. Otherwise injury may occur.
- When the head is removed to change the head orientation, the NC contact is turned on (closed). Make sure that the head is secured in place before installing the interlock switch.

Instructions

- Regardless of door types, do not use the interlock switch as a door stop. Install a mechanical door stop at the end of the door to protect the interlock switch against excessive force.
- Do not apply excessive shock to the interlock switch when opening or closing the door. A shock to the interlock switch exceeding 1,000 m/s² may cause damage to the interlock switch.
- When wiring the terminals, open the hinged lid only. Do not open any other part of the interlock switch.
- While connecting a cable gland or wiring the terminals, prevent foreign objects from entering the interlock switch, such as dust and liquids.
- If the operating atmosphere is contaminated, use a protective cover to prevent the entry of foreign objects into the interlock switch through the actuator entry slots.
- Entry of a considerable amount of foreign objects into the interlock switch may affect the mechanism of the interlock switch and cause a malfunction.
- Plug the unused actuator entry slot using the slot plug supplied with the interlock switch.
- Do not store the interlock switches in a dusty, humid, or organic-gas atmosphere.
- Use proprietary actuators only. When other actuators are used, the interlock switch may be damaged.
- Do not modify the actuator, otherwise it will damage the interlock switch.
- Although the HS9Z-A51A and HS9Z-A52A actuators (w/rubber bushings) alleviate shock when the actuator enters the slot in the interlock switch, make sure that excessive shocks are not applied. When the rubber bushings are deformed or cracked, replace with new ones.

- When door hinge is on the extension line of the actuator mounting surface:

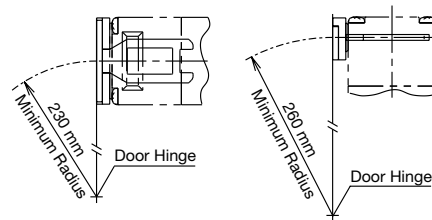

When using the HS9Z-A55 Angle Adjustable Actuator

- When door hinge is on the extension line of the interlock switch surface: 50 mm
- When door hinge is on the extension line of the actuator mounting surface: 70 mm

Horizontal Swing

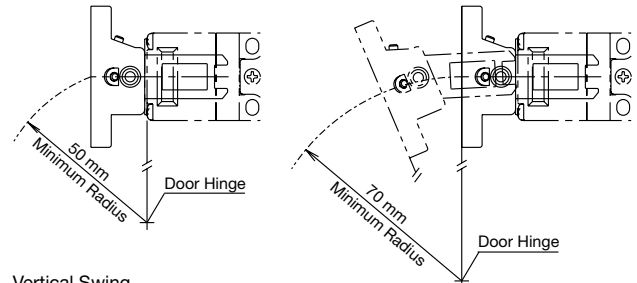

Vertical Swing

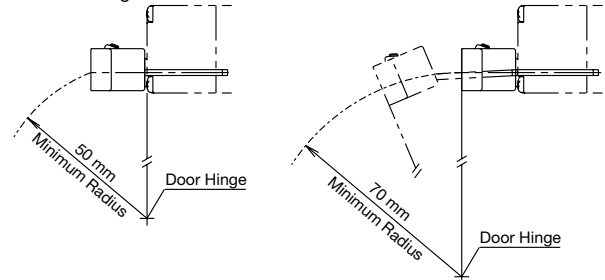

Minimum Radius of Hinged Door

- When using the interlock switch on hinged doors, refer to the minimum radius of doors shown below. When using on doors with small minimum radius, use the angle adjustable actuator (HS9Z-A55).

Note: Because deviation or dislocation of hinged doors may occur in actual applications, make sure of the correct operation before installation.

When using the HS9Z-A52 Actuator

- When the door hinge is on the extension line of the interlock switch surface:

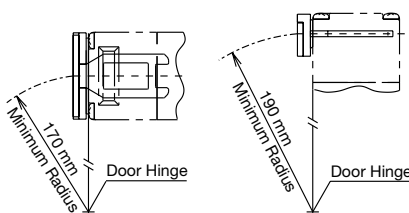

Actuator Angle Adjustment for the HS9Z-A55

- Using the angle adjustment screw, the actuator angle can be adjusted (see figures on page 4).
Adjustable angle: 0 to 20°
- The larger the adjusted angle of the actuator, the smaller the applicable radius of the door opening.
- After installing the actuator, open the door. Then adjust the actuator so that its edge can be inserted properly into the actuator entry slot of the interlock switch.
- After adjusting the actuator angle, apply Loctite to the adjustment screw so that the screw will not loosen.

HS5B Miniature Interlock Switches

Mounting Examples

- Mount the interlock switch as shown in the examples below.
- Mount the interlock switch on a fixated machine or guard, and mount the actuator on the hinged door. Do not mount both interlock switch and actuator on hinged doors, otherwise malfunction will occur.

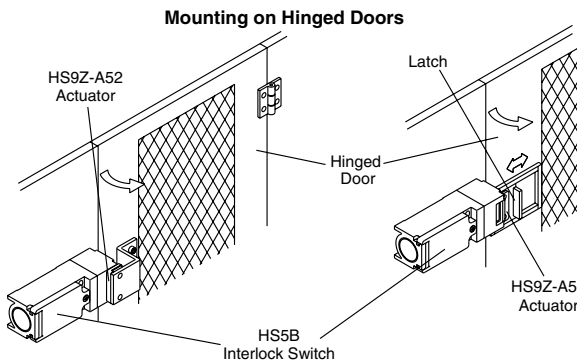
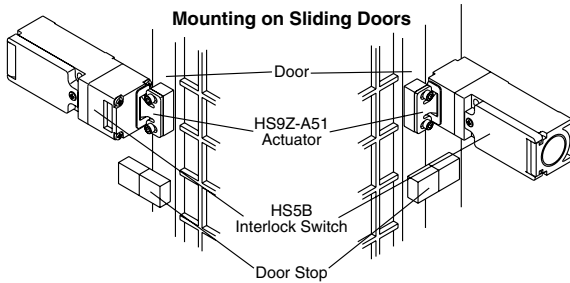

Mounting the HS5B Head

- The metal head for the HS5E interlock switch cannot be used on the HS5B. Be sure to use the plastic head or metal head for the HS5B. Take care particularly when using both HS5B and HS5E together.

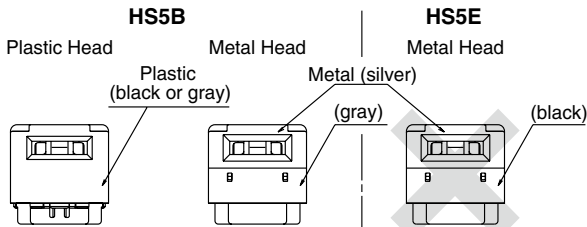

Note: Metal heads of the HS5B and HS5E can be identified by the color of plastic part.

Rotating the Head

- The head of the HS5B can be rotated by removing the four screws from the corners of the HS5B head and reinstalling the head in the desired orientation. When reinstalling the head, make sure that no foreign object enters the interlock switch. Tighten the screws tightly, because loose tightening may cause malfunction.
- Recommended screw tightening torque: 1.0 ± 0.1 N·m

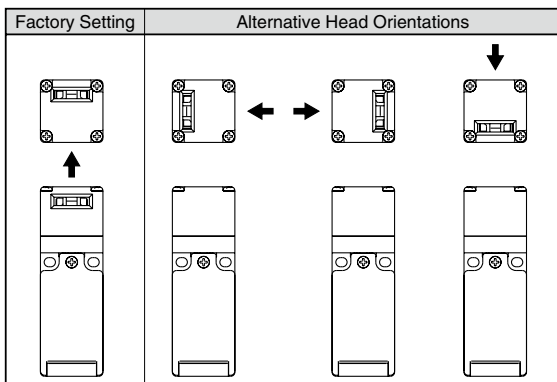

Applicable Crimping Terminal

- When using crimping terminals, be sure to install insulation tubes on the crimping terminals to prevent electric shocks.
- When using stranded wires, make sure that loose wires do not cause short circuit. Also, do not solder the terminal to prevent loose wires.

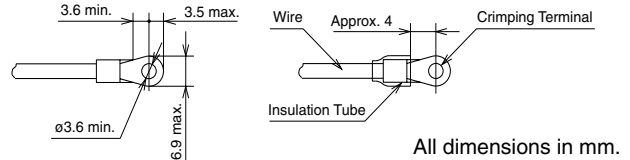

Applicable Wire Size

- 2 mm² maximum (AWG20 to AWG16)

Recommended Tightening Torque of Mounting Screws

- Interlock Switch: 1.8 to 2.2 N·m (two M4 screws) *
- Actuators
 - HS9Z-A51: 1.8 to 2.2 N·m (two M4 screws) *
 - HS9Z-A52: 0.8 to 1.2 N·m (two M4 Phillips screws) *
 - HS9Z-A51A/A52A: 1.0 to 1.5 N·m (two M4 screws) *
 - HS9Z-A55: 1.0 to 1.5 N·m (two M4 screws) *
- * The above recommended tightening torques of the mounting screws are the values confirmed with hex socket head bolts. When other screws are used and tightened to a smaller torque, make sure that the screws do not come loose after mounting.

- Mounting bolts must be provided by the users.
- To avoid unauthorized or unintended removal of the interlock switch and the actuator, it is recommended that the interlock switch and the actuator be installed in an unre-movable manner, for example using special screws or welding the screws.
- When installing the HS9Z-A51A or HS9Z-A52A actuators, use the washer (supplied with the actuator) on the hinged door, and mount tightly using two M4 screws.

Mounting centers:
12 mm (factory setting), adjustable to 20 mm

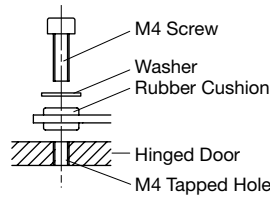

Note: Choose mounting centers either 12 mm or 20 mm.

Conduit Port Size Identification

- Conduit port size is identified by the arrow on the back of the HS5B interlock switch. The following example shows the identification of the M20 conduit port size.

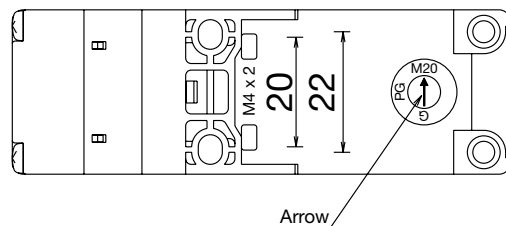

Marking	Conduit Port Size
G	G1/2
PG	PG13.5
M20	M20

Applicable Cable Glands

- Use a cable gland with a degree of protection IP67.

Applicable Cable Gland Dimensions

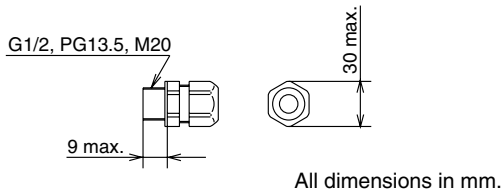

When Using Flexible Conduits (Example)

- Flexible conduit example: VF-03 (Nihon Flex)

Conduit Port Size	Plastic Cable Gland	Metal Cable Gland
G1/2	—	RLC-103 (Nihon Flex)
PG13.5	—	RBC-103PG13.5 (Nihon Flex)
M20	—	RLC-103EC20 (Nihon Flex)

When Using Multi-core Cables (Example)

Conduit Port Size	Plastic Cable Gland	Metal Cable Gland
G1/2	SCS-10* (Seiwa Electric)	ALS-16** (Nihon Flex)
PG13.5	ST13.5 (K-MECS)	ABS-***PG13.5 (Nihon Flex)
M20	ST-M20X1.5 (K-MECS)	ALS-***EC20 (Nihon Flex)

- Different cable glands are used depending on the cable sheath outside diameter. When purchasing a cable gland, confirm that the cable gland is applicable to the cable sheath outside diameter.
- When using a 1/2-14NPT cable gland, use the HS5B interlock switch with M20 conduit port (Part No.: HS5B-***BM) together with an adapter (Part No.: MA-M/NPT 20X1.5 5402-0110, K-MECS) and a gasket (Part No.: GP M20, K-MECS). Install a gasket between the interlock switch and the adapter. Apply sealing tape between the cable gland and the adapter to make sure of IP67 protection for the enclosure.