



INSTRUCTION SHEET
Original Instructions
Interlock Switch
HS1B / HS2B Series



Thank you for purchasing this IDEC product. Confirm that the delivered product is what you have ordered. Read this instruction sheet to make sure of correct operation.

SAFETY PRECAUTIONS

In this operation instruction sheet, safety precautions are categorized in order of importance to Warning and Caution :

⚠ WARNING

Warning notices are used to emphasize that improper operation may cause severe personal injury or death.

⚠ CAUTION

Caution notices are used where inattention might cause personal injury or damage to equipment.

1 Type

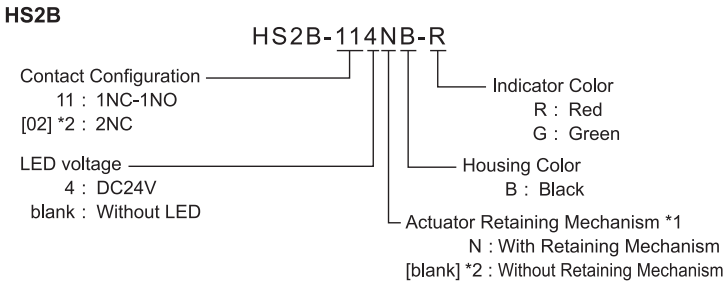
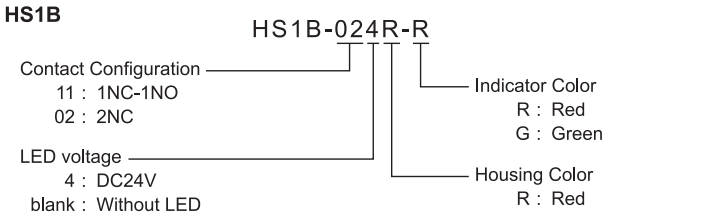

*1 HS2B is equipped with a retaining mechanism, that prevents easy separation of the actuator from the switch.
*2 Type No. in [] are not supplied as standard. Contact IDEC if required.

2 Specifications and Ratings

Applicable Standards	EN ISO / ISO14119 IEC60947-5-1, EN60947-5-1 GS-ET-15, UL508 CSA C22.2 No.14					
Standards for Use	IEC60204-1/ EN60204-1					
Interlocking device Type / the level of coded	Type 2 Interlocking device / low level coded actuator (EN ISO / ISO14119)					
Applicable Directives	Low Voltage Directive, Machinery Directive, RoHS Directive					
Operating Condition	Operating Temperature	-20 to +70°C (no freezing)				
	Operating Humidity	45 to 85%RH (no condensation)				
	Storage Temperature	-40 to +80°C (no freezing)				
	Pollution Degree	3				
	Altitude	2,000m maximum				
Inpulse withstand voltage (Uimp)	4kV					
Raed Insulation voltage (Ui)	300V (Between ground and LED : 30V)					
Thermal Current (Ith)	10A					
Contact Ratings (Reference Values) (Ue , Ie)	AC	Resistive load (AC-12)	30V	125V	250V	
		Inductive load (AC-15)	10A	10A	6A	
	DC	Resistive load (DC-12)	10A	5A	3A	
		Inductive load (DC-13)	8A	2.2A	1.1A	
	Class of Protection		HS1B : Class I (IEC61140) HS2B : Class II (IEC61140) <input type="checkbox"/> *3			
	Operating Frequency		900 operations / hour			
Operating Speed		0.05 to 1.0 m / s				

B10d	2,000,000 (EN ISO 13849-1 Annex C Table C.1)	
Mechanical Durability	1,000,000 operations min. (GS-ET-15)	
Electrical Durability	100,000 operations min. (900 operations / hour, Rated Load)	
Shock Resistance	Damage Limits : 1,000m/s ²	
Vibration Resistance	Operating Extremes :10 to 55Hz, half amplitude 0.5mm Damage Limits : 30Hz, half amplitude 1.5mm	
Direct Opening Travel	11 mm minimum	
Direct Opening Force	HS1B, HS2B (Without Retaining Mechanism) : 20N minimum HS2B (With Retaining Mechanism) : 36N minimum	
Contact Resistance	50 mΩ maximum (Initial value)	
Degree of Protection	IP67 (IEC60529)	
Conditional short circuit current	100A(250V)	
Short-Circuit Protective Device	250V AC,10A fast acting type fuse	
Indicator	Rated Operating Voltage	DC24V
	Rated Current	10mA
	Light Source	LED lamp
	Illumination Color	R(Red), G(Green) (Φ12Lens)
Weight	HS1B : Approx.280g, HS2B : Approx.130g	

*3 Basic insulation of 4kV impulse withstand voltage is ensured between different contact circuits and between contact circuits and LED or solenoid in the enclosure. When both SELV (safety extra low voltage) or PELV (protective extra low voltage) circuits and other circuits (such as 230V AC circuits) are used for the solenoid power and contact circuits at the same time, the SELV or PELV requirements are not met any more.

Ratings approved by safety agencies

- (1) TÜV rating
AC-15 250V, 3A
- (2) UL, c-UL rating
3A, 250V ac, General Use
3A, 250V ac, Resistive
3A, 30V dc

3 Mounting Examples

• Install the interlock switch on the immovable machine or guard, and install the actuator on the movable door. Do not install both interlock switch and actuator on the movable door, otherwise the angle of insertion of the actuator to the interlock switch may become inappropriate, and failure will occur.

(Examples of Mounting on Sliding Doors) (Examples of Mounting on Hinged Doors)

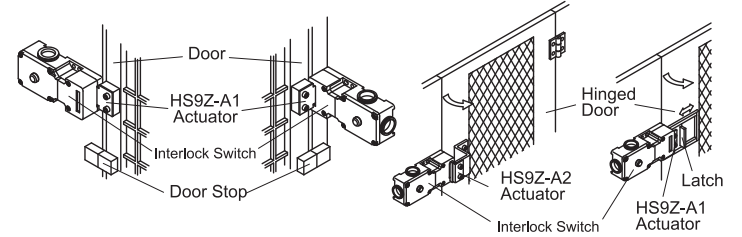

Minimum Radius of Hinged Door

When using the interlock switch for a hinged door, the minimum radius of the applicable door is shown in the following figures.

When the center of the hinged door is on the extension line of the actuator mounting surface. When the center of the hinged door is on the extension line of the contact surface of actuator and interlock switch.

• L-shaped actuator : HS9Z-A2

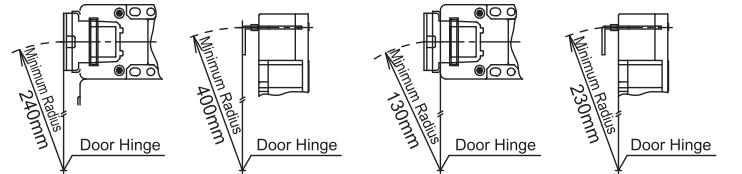

• Adjustable actuator : HS9Z-A3

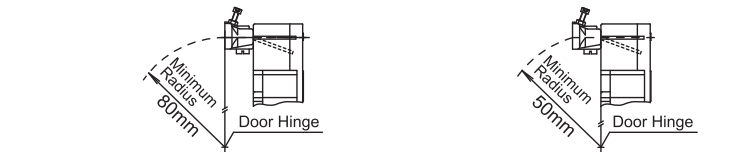

⚠ CAUTION

The figures shown above are based on the condition that the actuator enters and exits the actuator entry slot smoothly when the door is closed or opened. Since there may be deviation or dislocation of the hinged door, make sure of correct operation in the actual application before installation.

Actuator Mounting Reference Position

As shown below, the mounting reference position of the actuator inserted into the interlock switch is the actuator cover or stop film touches the interlock switch lightly. (After mounting the actuator, remove the actuator cover or stop film from the interlock switch.)

Note : During installation, ensure that there is no excess force applied between the interlock switch and actuator by installing a door stopper as shown in the image.

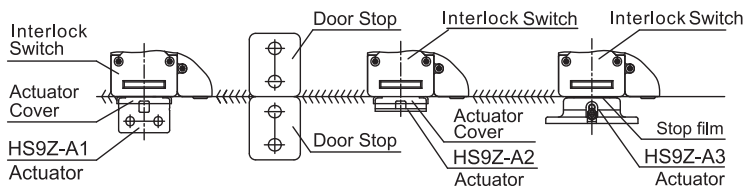

Actuator Mounting Tolerance

Mounting tolerance of the actuator is 1.0mm from the center of the actuator to up, down, right, and, left.

Make sure the actuator can be inserted into the entry slot without any issue.

Actuator can move 3.8mm (HS9Z-A1 and -A2) / 2.7mm (HS9Z-A3) from the mounting position without affecting the contact operation.

$$\left(\text{Deviation of actuator position} \right) + \left(\text{Deviation of door position} \right) \leq 3.8 / 2.7 \text{mm}$$

When closing the door (when actuator is inserted into interlock switch), the solenoid is locked as the actuator has reached at approx. 6.4mm (HS9Z-A1 and -A2) / 5.3mm (HS9Z-A3) to the mounting reference position.

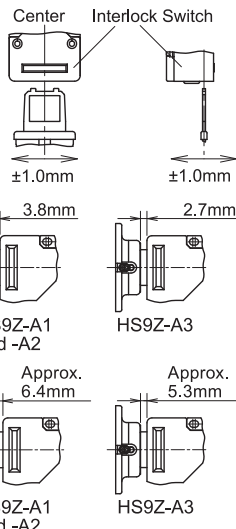

Recommended Screw Tightening Torque

Name or Use	Screw Tightening Torque	
For mounting the interlock switch (M5 hexagon socket head cap screw) *4	HS1B	4.5~5.5 N·m
	HS2B	3.2~3.8 N·m
For mounting the actuator (M6 hexagon socket head cap screw) *4	4.5~5.5 N·m	
For mounting the lid (M4)	HS1B	1.1~1.3 N·m
	HS2B	0.8~1.0 N·m
Connector (G1/2)	2.7~3.3 N·m	
Plug for Unused Conduit Hole (G1/2)	1.8~2.2 N·m	
Terminal screw (M3.5)	0.9~1.1 N·m	
Ground Terminal screw (M4)	0.9~1.1 N·m	
Angle adjusting screw of HS9Z-A3 (M3 hexagon socket head cap screw)	0.8 N·m	

CAUTION

*4 When the torque is not enough to recommended screw tightening torque, make sure that the screw do not become loose by using adhesive sealants etc. to keep right operation and mounting positioning.

Adjusting the Angle Adjustable Actuator (HS9Z-A3)

Using the angle adjusting screw (M3 hexagon socket head screw), the actuator angle can be adjusted up to 20°.

The larger the actuator angle, the smaller the applicable radius of the door swing. After installing the actuator, open the door. Then adjust the actuator angle so that the actuator enters the entry slot of the interlock switch properly.

After adjusting the actuator angle, apply loctite or the like on the adjusting screw to prevent loosening.

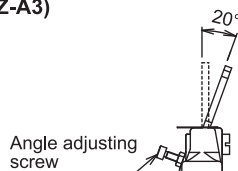

Installing the slot plug (In the case of a standard sale item. Please check other models.)

When not in use, close up the interlock switch actuator entry slots with slot plugs to prevent dust from entering.

The actuator entry slot vertical to the mounting panel come closed up with slot plugs at time of shipment.

When replacing, please use the tool as shown.

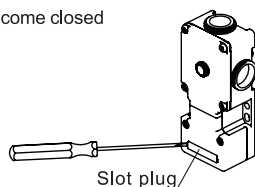

4 Instruction

Installation

Do not apply an excessive shock to the interlock switch when opening or closing the door. A shock to the interlock switch exceeding 1,000 m/s² may cause failure.

Provide a door guide, and ensure that force is applied on the interlock switch only in the actuator insertion direction.

Entry of foreign objects in the actuator entry slot may affect the mechanism of the switch and cause a breakdown. If the operating atmosphere is contaminated, use a protective cover to prevent the entry of foreign objects into the switch through the actuator entry slots.

Make sure to install the product in a place where it cannot be damaged. Make sure to conduct a proper risk assessment evaluation before using the product, and use a shield or a cover to protect the product if need be.

When opening the interlock switch lid to wire, open the lid ① only. (See the figure on the right.) Never remove other screws, otherwise the interlock switch may be damaged.

The interlock switch cover can be only removed or installed with the special L-shaped key wrench supplied with the switch. (applicable HS1B only)

Avoid foreign objects such as dust, liquid, and oil from entering the switch while connecting a conduit or wiring.

Use only the designated actuator for the HS1B / HS2B. Other actuators will cause a breakdown of the switch.

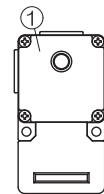

L-shaped wrench attached to the interlock switch
Type: HS9Z-T1



Opening the connector hole (only HS2B)

The HS2B interlock switch has 3 conduits hole knockouts formed on the switch housing. Break a desired knockout to mount a connector using a hammer or a screwdriver.

When breaking the knockout to open a connector hole, be careful not to damage the contact block inside.

Use an optional connector hole plug to close an unused connector hole.

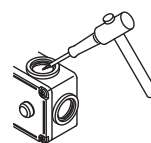

Plug type : HS9Z-P1

WARNING

Turn off the power to the interlock switch before starting installation, removal, wiring, maintenance, and inspection on the interlock switch. Failure to turn power off may cause electrical shocks or fire hazard.

Use wires of a proper size to meet voltage and current requirements. Tighten the terminal screws to a recommended tightening torque of 1.0N·m. Loose terminal screws will cause unexpected heating and fire hazard during operation.

CAUTION

HS1B / HS2B Series Interlock Switches are Type 2 low-level coded interlocking devices (EN ISO / ISO14119). The following system installation & mounting instructions are EN ISO / ISO14119 requirements to prevent function failure from the interlock switch.

- Using permanent fixing methods (e.g. welding, rivets, special screws...etc) to prevent dismantling or de-positioning of the interlock device. However, permanent fixing methods are not an adequate solution if you expect the interlock device to fail during the machinery lifetime, or if you need to replace the product in quick manner. In these situations, other measures (see 2.) should be put in place to reduce the risks of function failure.

- At least one of the following measures should be applied to prevent function failure.

- Mounting the interlock device in a place out of reach from workers
- Using shielding protection to prevent physical obstruction of the device
- Mounting the interlock device in a hidden position
- Integrate status monitoring & cycling testing of the device to the control system to prevent product failure.

Regardless of door types, do not use the interlock switch as a door stop. Install a mechanical door stop at the end of the door to protect the interlock switch against an excessive force.

Mount the actuator so that it will not hit the operator when the door is open, otherwise injury may be caused.

Pay attention to the management of spare actuator. Safety function of door interlock switch will be lost in case the spare actuator is inserted into the interlock switch. Ensure that the actuator is firmly fastened to the door (welding, rivet, special screw) in the appropriate location, so that the actuator cannot be removed easily.

Do not cut or remodel the actuator, otherwise failure will occur.





If multiple safety components are wired in series, the Performance Level to ISO13849-1 will be reduced due to the restricted error detection under certain circumstance.

The insulation of the cable has to withstand environmental influences.

The entire concept of the control system, in which the safety component is integrated, must be validated to ISO13849-2.

5 Contact Operation

Contact Configuration

Type	Contact Configuration *5	
	Indicator (+)—○—(-)	Door monitor 
HS1B-11	Main Circuit : ⊖ 3 — 4 Monitor Circuit : 1 — 2	
HS1B-02	Main Circuit : ⊖ 3 — 4 Monitor Circuit : ⊖ 1 — 2	
HS2B-11	Main Circuit : ⊖ 3 — 4 Monitor Circuit : 1 — 2	
HS2B-02	Main Circuit : ⊖ 3 — 4 Monitor Circuit : ⊖ 1 — 2	

⚠ CAUTION

*5 The Actuator is inserted, and HS1B /HS2B is locked.

6 Wiring

Wire Length inside the Interlock Switch

Screw Terminal No.	Through Conduit Hole				
	①	②	③		
	HS1B	HS2B	HS1B, HS2B	HS1B, HS2B	
Wire Length : L1(mm)	1	60±2	45±2	30±2	80±2
	2	60±2	45±2	80±2	30±2
	3	30±2	20±2	30±2	50±2
	4	30±2	20±2	50±2	30±2
	+	45±2	35±2	25±2	70±2
	-	45±2	35±2	70±2	25±2
	E	70±2	-	95±2	40±2
Wire Stripping Length : L2 (mm)	7±1				

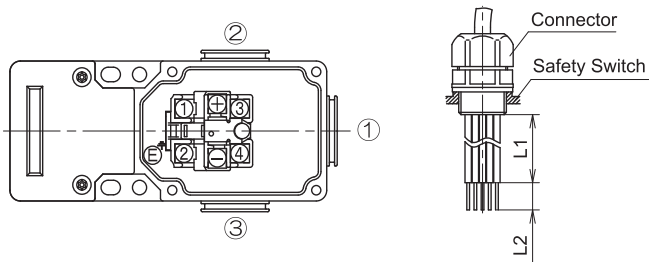

Recommended Wire Core Size

0.5 to 1.25mm²

Applicable Crimping Terminal

Terminal Screw (M3.5)

Ground Terminal Screw (M4)

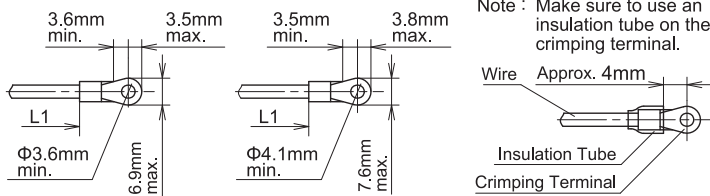

Applicable Connectors

Use a connector with a degree of protection IP67.

- When using plastic connector, metal connector and multi-core cable (G1/2)

Applicable Plastic Connector Example : Type SCS-10□ (made by Seiwa Electric)
Applicable Metal Connector Example

: Type C20G-□□16 (made by SANKEI MANUFACTURING)

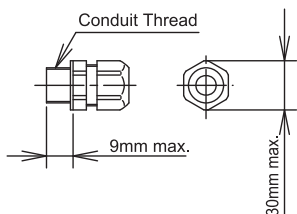

Note : Confirm the outside diameter of the multi-core cable, the connector type depends on the outside diameter of multi-core cable.

7 Example of wiring Diagram realizing Safety Category

**Example of a circuit diagram for Safety Category 3
(attainable PL = d)**

(Condition 1: To apply the fault exclusion of mechanical structural parts including the actuator
→ Make sure to use the product within the product specification range described in this manual and the version of the manual provided with the product.)
(Condition 2: Documentation of the reason for the machine/equipment manufacturer to have applied the fault exclusion based on ISO13849-1, ISO13849-2 or IEC62061.)

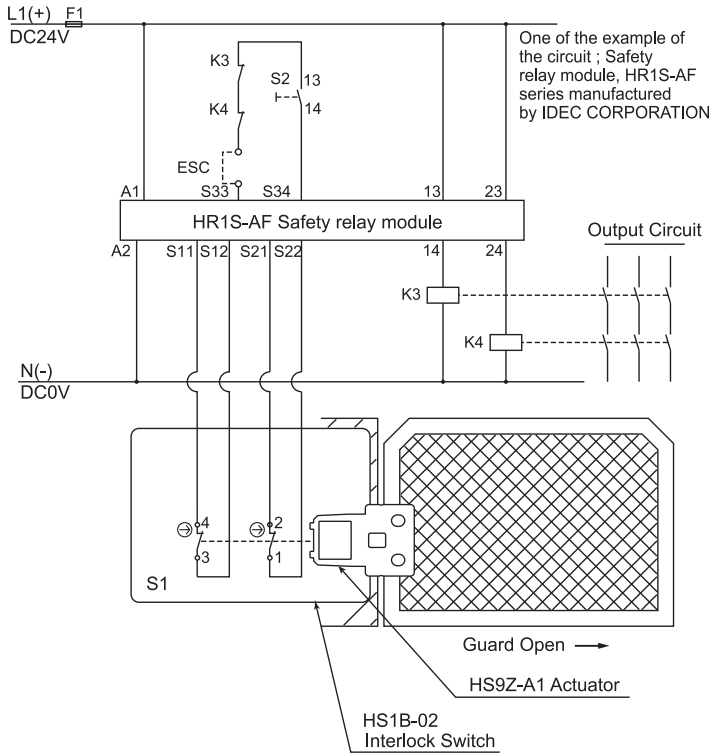

- S1: HS1B-02 Interlock Switch with Solenoid
- S2: Start Switch (HW Series Momentary)
- S3: Safety limit Switch
- ESC: Outside start condition
- K3, 4: Safety Contactor
- F1: Outside fuse of safety relay module at power supply line

**Example of a circuit diagram for Safety Category 4
(attainable PL = e)**

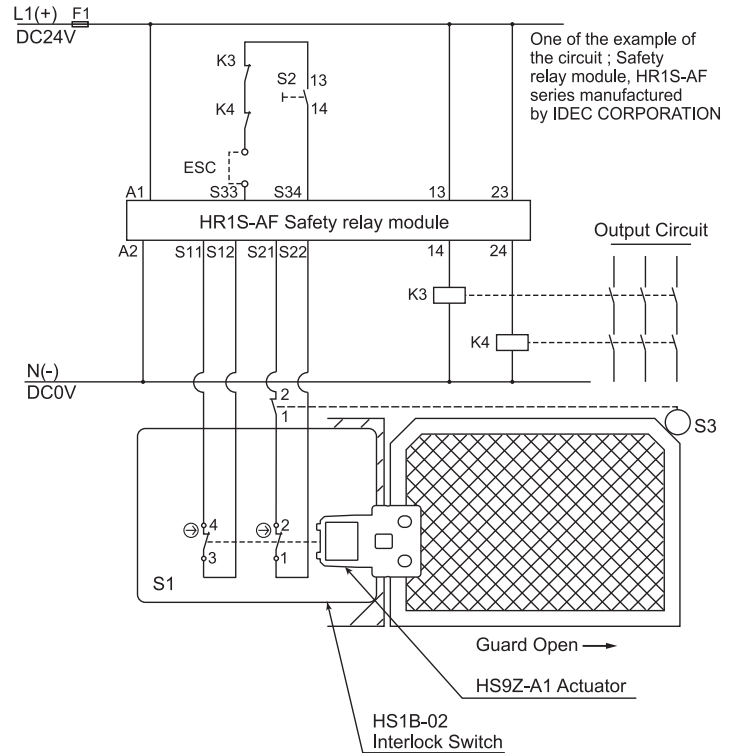

Note: Use the monitoring device(Safety relay module) provided the capability to detect a cross short circuit. The insulation of the cable has to withstand environmental influences. If a control device other than the one shown in the draft is used, the used control device has to be equipped with a cross short circuit monitor.

8 Dimensions (mm)

Interlock Switch

dimensions Type : HS1B

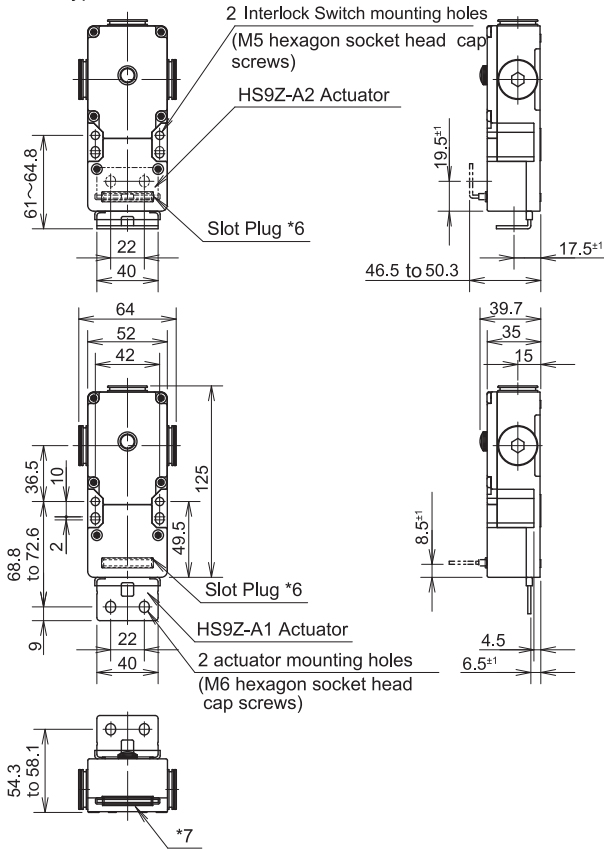

*6 The actuator entry slot vertical to the mounting panel
*7 The actuator entry slot horizontal to the mounting panel
Note: When not in use, close up the interlock switch actuator entry slots with slot plugs to prevent dust from entering.
(The actuator entry slot vertical to the mounting panel come closed up with slot plugs at time of shipment.
In the case of a standard sale item. Please check other models.)

Type : HS2B

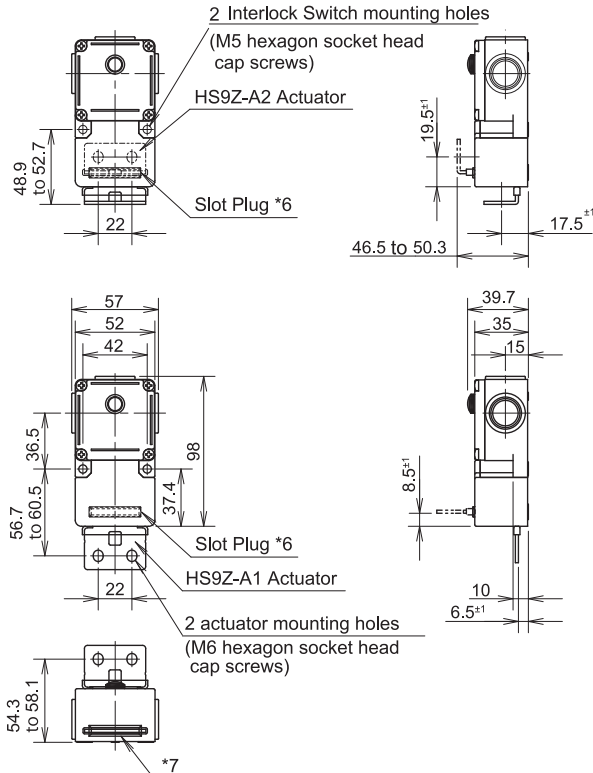

Accessories dimensions

Type : HS9Z-A1

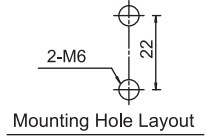
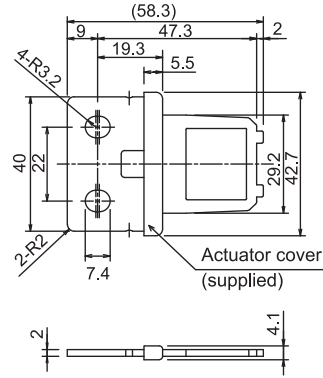

Type : HS9Z-A2

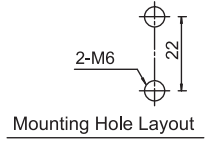
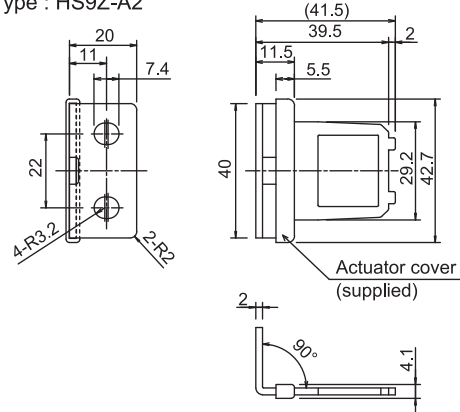

Type : HS9Z-A3

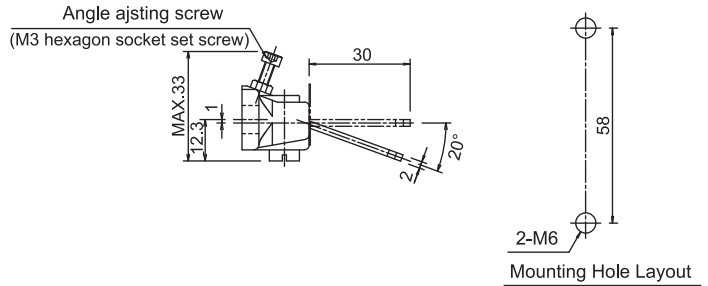
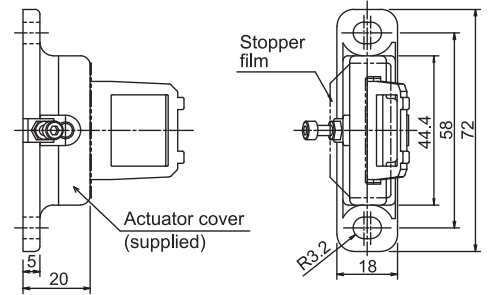

9 Precaution for Disposal

Dispose of the HS1B / HS2B Interlock switch as an industrial waste.

IDEC CORPORATION

<http://www.idec.com>

Manufacturer: IDEC CORP.
2-6-64 Nishimiyahara Yodogawa-ku, Osaka 532-0004, Japan
EU Authorized Representative: APEM SAS
55, Avenue Edouard Herriot BP1, 82303 Caussade Cedex, France

EU DECLARATION OF CONFORMITY
We, IDEC CORPORATION 2-6-64, Nishimiyahara Yodogawa-ku, Osaka 532-0004, Japan declare under our sole responsibility that the product:

Description: Interlock Switch
Model No: HS1B / HS2B
Applied Union harmonized legislation and references to the relevant harmonization standards used or references the other technical specifications in relation to which conformity is declared.
Applicable EU Directive : Low Voltage Directive (2014/35/EU)
Machinery Directive (2006/42/EC)
RoHS Directive (2011/65/EU)
Applicable Standard(s) : EN 60947-5-1, GS-ET-19, EN IEC 63000

UK Authorized Representative: APEM COMPONENTS LIMITED
Drakes Drive, Long Crendon, Buckinghamshire, HP18 9BA, UK
Applicable UK Directive : Electrical Equipment (Safety) Regulations 2016,
Supply of Machinery (Safety) Regulations 2008,
The Restriction of the Use of Certain Hazardous Substances in
Electrical and Electronic Equipment Regulations 2012
Applicable Standard(s) : EN 60947-5-1, EN IEC 63000, EN ISO 14119